

# PRODUCT DATASHEET

## DOWNLIGHTS | DAMP-PROOF LUMINAIRES

Downlights | Surface mounted spotlight 15w | Round shape

Code# DPR13001-15



---

### Areas of Application

- Hotel
- Villa
- Apartment
- Homestay
- Bathroom, kitchen, corridor, toilet, residential interiors

---

### Product Features

- IP54, moisture-proof, dust-proof, insect-proof
- High luminous efficacy, high CRI
- Energy savings of up to 90% compared to halogen lamp spotlights
- CCT optional and dimmable
- High transmission lampshade
- Anti-glare, without flicker
- Easy and quick installation

---

## Complete Product Data

<b>Code#</b>	DPR13001-15
<b>Wattage</b>	15w
<b>Installation Type</b>	Surface
<b>Dimension</b>	φ330mm*H95mm
<b>Cutout</b>	/
<b>IP Rating</b>	IP54
<b>Luminous Flux</b>	1050lm
<b>Beam Angle</b>	120°
<b>Working Temperature</b>	-25°C ~55°C
<b>Certificates</b>	/
<b>Warranty</b>	3 Years
<b>Packing Size</b>	/

## Driver Data

<b>Driver Brand</b>	Tridonic, Osram, Philips, Lifud, Euchips, Eaglerise, etc.
<b>Input Voltage</b>	100-250VAC 50/60hz
<b>Output Voltage</b>	27-40Vdc
<b>Output Current</b>	350mA
<b>Power Factor</b>	>0.5 as standard; >0.9 optional
<b>Efficiently</b>	87% @230v
<b>IP Rating</b>	IP20
<b>Dimmable</b>	Non-Dimmable/Triac/0-10v/Dali Optional
<b>Free Flicker</b>	Yes
<b>Certificates</b>	CE, CB, CCC, ENEC
<b>Warranty</b>	3/5 Years

## Material&Housing Data

<b>Housing Color</b>	White
<b>Reflector Color</b>	/
<b>Housing Material</b>	ABS+PC

## Photometric Data

<b>LED chip brand</b>	Cree/ Osram /Bridgelux/ Epistar etc.
<b>Chip Type</b>	SMD
<b>Color Temperature</b>	3000K, 4000K, 6000K
<b>CRI</b>	>80
<b>Life time</b>	>50000Hrs
<b>Lumens efficacy</b>	100-120lm/w

---

## Dimensions&Installation

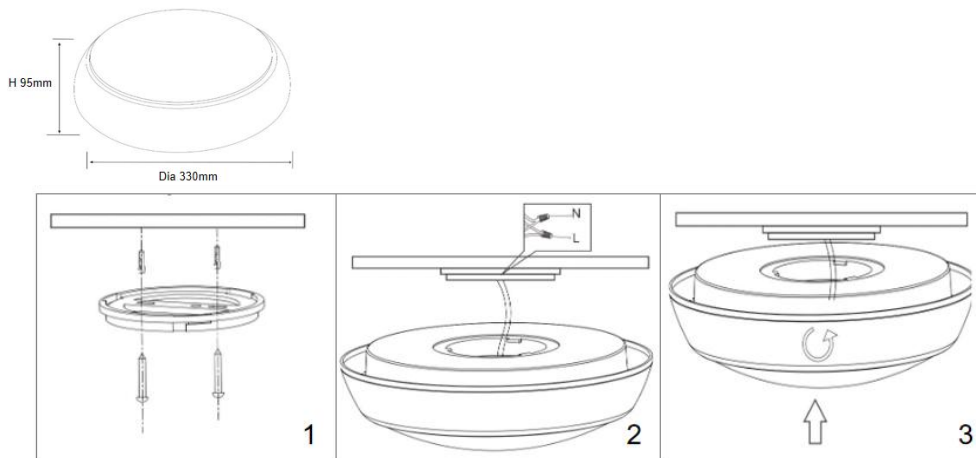

**PLEASE FIND A QUALIFIED ELECTRICIAN FOR INSTALLATION.** Please read the instructions before you install and use the downlight.

1. Make sure the power is turned off in which you are installing the products.
2. Fix the screws through the underbed. (Fig 1)
3. Connecting the L/N wire accordingly in the junction box. (Fig 2)
4. Hold the lamp and rotate clockwise. (Fig 3)
5. Restore power at the source and the installation is complete.